



Project _____
 AIA # _____ SIS # _____
 Item # _____ Quantity _____ C.S.I. Section 114000



HS SLICER SERIES – HS4N

HS4N Manual Heavy-Duty Slicer



SPECIFIER STATEMENT

Specified slicer will be an NSF rated heavy-duty manual HS slicer with a patented removable knife option and 13" chrome plated carbon steel knife. Slicer offers top-mounted ceramic sharpener, heavy-duty stainless steel knife cover and rear mounted, removable meat/vegetable grip arm. Tilting, removable carriage and spring kickstand provide complete access for deep cleaning. Base is constructed from sanitary burnished aluminum to limit crevices and allow for easy cleanup. Features ½ HP knife drive motor and machined grooves on gauge plate.

MODELS

- HS4N** Manual slicer with non-removable knife

STANDARD FEATURES

Features in bold are exclusive to Hobart

- + ½ HP knife drive motor
- + 13" chrome plated carbon steel knife
- + Top-mounted ceramic stone sharpener
- + Burnished aluminum base
- + **Tilting and removable carriage system**
- + Heavy-gauge stainless steel knife cover
- + Electroless nickel plated, single slide rod with reservoir wick in transport
- + No-volt release
- + Spring kickstand
- + Ergonomic style handle
- + Rear mounted, removable meat/vegetable grip arm
- + Machined grooves on gauge plate

ACCESSORIES (Available at extra cost)

- + Full fence
- + Food chute
- + Debris deflector

Approved by _____ Date _____ Approved by _____ Date _____

SOLUTIONS / BENEFITS

PERFORMANCE

13" Chrome Plated Carbon Steel Knife

Machined Grooves on Gauge Plate

- + Reduces drag for smooth slicing motion

½ HP Knife Drive Motor

- + The power needed to slice cheese and meat with no shredding

Top-Mounted Ceramic Stone Sharpener

- + Single action, hones in 15 seconds

Heavy-Duty Stainless Steel Knife Cover

EASE OF USE

Spring Kickstand

- + Helps user get underneath slicer to clean

Rear Mounted, Removable Meat/Vegetable Grip Arm

- + Opens for unobstructed loading

Tilting and Removable Carriage

- + Makes it easy to keep slicer clean and sanitary

Top-Mounted Ceramic Stone Sharpener

- + Single action removable sharpener, hones in 15 seconds

SANITATION & CLEANING

Burnished Aluminum Base

- + Has fewer crevices where bacteria may grow

Spring Kickstand

- + Makes it easy to clean underneath the slicer

Tilting and Removable Carriage

- + Makes it easy to keep slicer clean and sanitary

Rear Mounted, Removable Meat/Vegetable Grip Arm

- + Removable for easy cleaning

Top-Mounted Ceramic Stone Sharpener

- + Removable and warewasher safe

OPERATOR ASSURANCE

Top-Mounted Ceramic Stone Sharpener

- + Single action, hones in 15 seconds
- + Removable and warewasher safe

No-Volt Release

- + In the event of a power loss, slicer must be restarted before operation can continue



SPECIFICATIONS

Motor: 1/2 HP knife drive motor, knife is driven by a Hobart Poly V-Belt and runs at 430 RPM for optimal performance.

Electrical: 120/60/1; 5.6 amps.

Controls: Moisture protected push button switch.

Cord and Plug: 6 foot, three-wire power supply cord and plug. Plug not furnished on export models.

Construction: One-piece, sanitary burnished aluminum base. Fewer places to harbor debris; limits crevices or holes in which food can lodge. Product tray and gauge plate also burnished aluminum. Stainless steel top cover.

Capacity: The carriage will take food up to 5.75" x 10.75" rectangle or 7.5" in diameter.

Gauge Plate: Gauge plate is a heavy aluminum extrusion with machined grooves for smooth feeding. Adjustable to cut any thickness of slice up to 1".

Knife: The knife is approximately 13", constructed of 304L stainless steel and high performance Stellite alloy. Knife cover is retained magnetically, and is quickly removed by pulling straight back on the top cover knob.

Removable Ring Guard Cover: Fits on top of ring guard to catch food debris. When removed, reveals a 0.12" space between knife and guard for easier flossing. Ring guard is made with Zytel™ plastic and can be washed in warewasher or three compartment sink.

Top-Mounted Ceramic Stone Sharpener: Single action operation utilizing two Borazon® stones to sharpen and hone in five seconds. Removable, top mounted and warewasher safe. When sharpener is removed for cleaning, knife edge is completely shielded. Borazon® stones have a lifetime guarantee.

Warranty: All parts and service coverage for one year including knife. Lifetime guarantee on Borazon® stones in the sharpening system.

Shipping Weight: 128 lb.

Plugs and Receptacles:

Machine Voltages	
Service Current Requirement if Plug Connected	120/60/1
	15 Amp.
Terminal Designation of Plug	2 Pole 3 Wire Grounding
NEMA Plug Configuration	5-15P
Plug Configuration	
Molded Plug on Cord	Yes
Plug - Straight/Angle	Straight
NEMA Receptable or Connector Configuration	5-15R



HS4N Manual Heavy-Duty Slicer

DETAILS AND DIMENSIONS

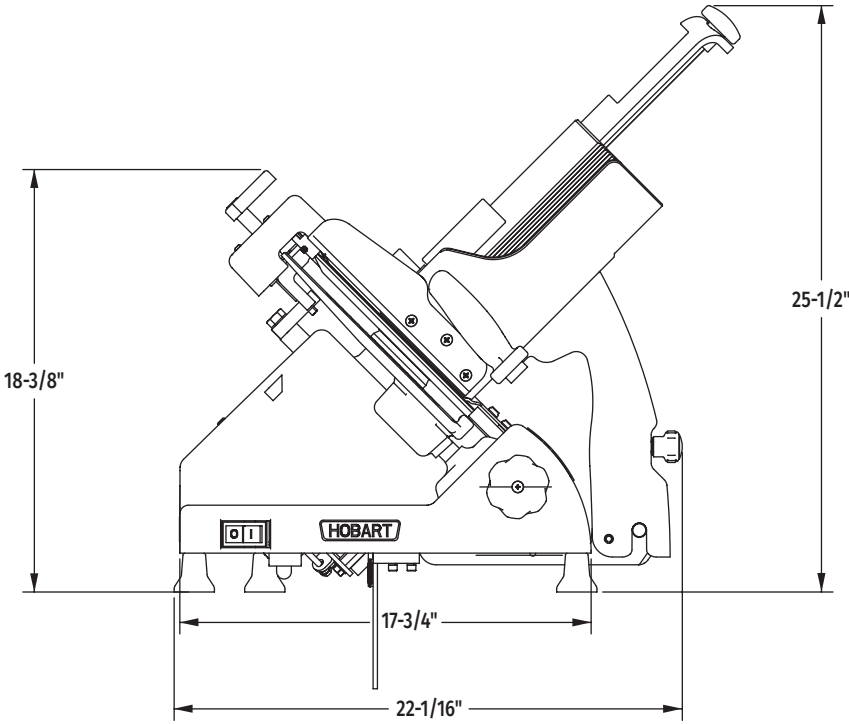
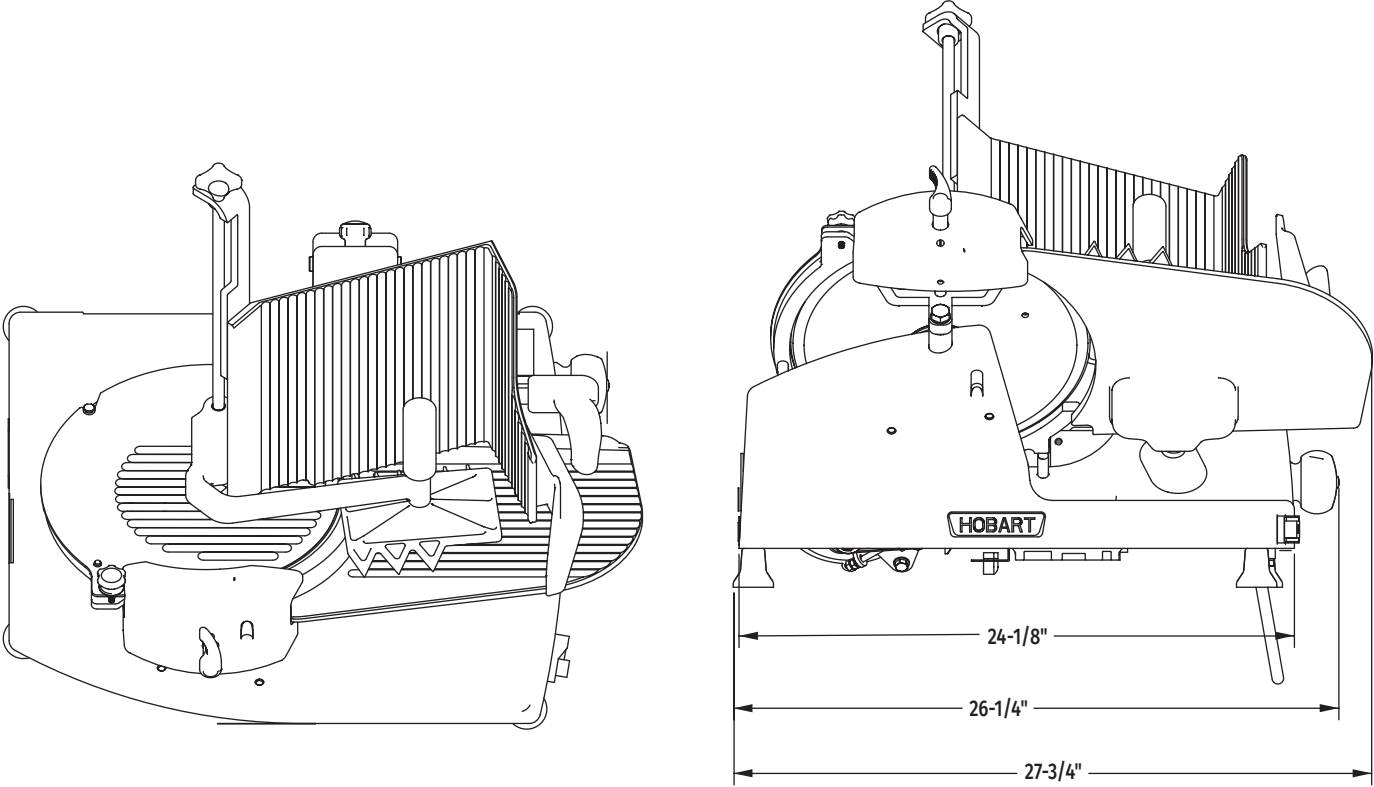

As continued product improvement is a policy of Hobart, specifications are subject to change without notice.

CAD and/or Revit Files Available